

HEAT EXCHANGERS



HEAT EXCHANGERS



OTT air-oil heat exchangers are used for cooling oil hydraulic systems using as the coolant ambient air that passes over the radiant by means of a fan operated by an electric or hydraulic motor. The cooler element, in high resistance aluminium alloy, is obtained by means of a braze-welding process carried out under vacuum. The particular configuration of the cooling pipes increase the turbulence of the fluid consequently of the exchange capacity; moreover, the presence of special jets on the cooler finning further improves the total transmission coefficient.

Compatible fluids

- . MINERAL OILS; HL; HLP.
- . WATER-OIL EMULSION.
- . WATER-GLYCOL.

Technical specification of Cooler Element

- . Material: "long life" aluminium.
- . Operating pressure: 20 bar
- . Test pressure: 35 bar.
- . Max operating temperature: 120°C.

Installation

The exchangers can be fitted in a horizontal position, respecting the minimum distance from the wall (see fig.1) so as to ensure a natural flow of cooling air.

The exchangers is usually installed on oil tank return piping; it must also be protected from impacts and mechanical vibrations by supports and must be connected to the plant with flexible pipes.

Avoid subjecting the exchanger to sudden changes in flow, hammering and pulsations that can cause irreversible damage to the element. We recommend installing a by-pass valve (see fig.2) to protect the exchanger from over-pressure generated when the plants is started up due to high oil viscosity.

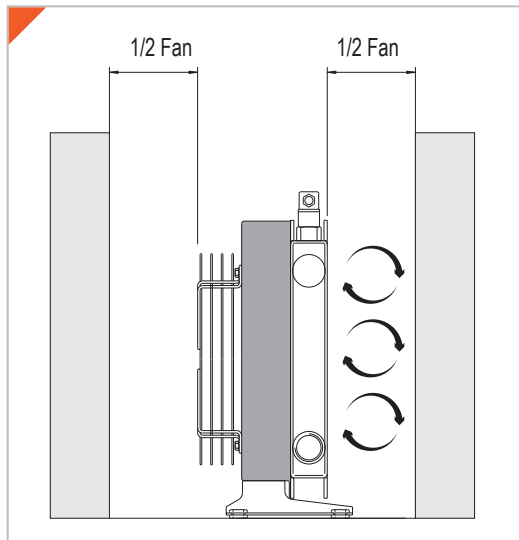

Fig.1

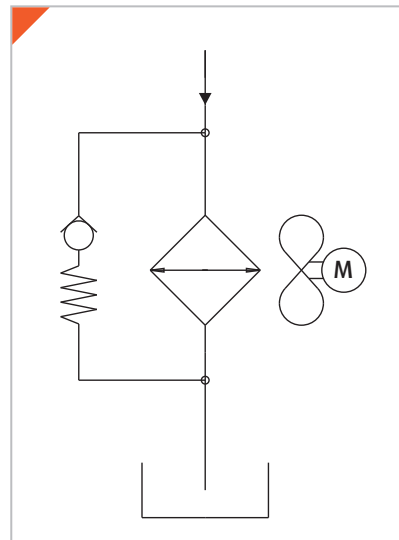

Fig.2

Maintenance

You should be particularly carefully in cleaning the cooler element to guarantee a natural exchange of air, in order to prevent a reduction in thermal efficiency

Cleaning Oil Side

The exchanger should be dismantled to clean on the oil side. The dirt can be removed by flushing, in counter-current, de-greasing substance, compatible with aluminium. Wash with hydraulic oil before re-connecting the product to the plant.

Cleaning Air Side

Cleaning on the air side can be done using compressed air or water, directing the jet parallel to the fins so as not to damage them. Oily dirt or grease can be removed with a jet of steam or hot water. During this operation, the electric motor must be disconnected from the voltage supply, and must be adequately protected.

Example of How to Choose a Heat Exchanger

Proceed with sizing the exchanger, with a knowledge of the data as the example below shows:

Power To Dissipate Iso	8,7 KW
Vg 32 Oil Flow Oil Input	90 lpm
Temperature Ambient	60 °C
Temperature	30 °C

Fan operating with an electric motor 230V-50Hz.

You can then calculate the specific heat exchange power KW/°C if you know the power to dissipate and the ΔT (the difference between the oil input temperature and the ambient temperature).

$$P = \frac{8,7 \text{ KW}}{60^\circ - 30^\circ} = 0,29 \text{ KW}/^\circ\text{C}$$

Note the oil flow (90 lpm) and specific exchange power (0.29 KW/°C), product research is made by referring to the graph in the catalogue which is relevant to each model.

The exchanger selected is the following model:
OS2030 - 01S/T03F

12-24V DC Electric Wiring

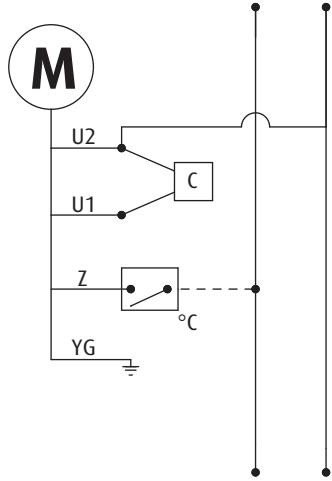

YG= Ground
 U1= Blue
 U2= Black
 Z = Brown
 C = Capacitor
 °C= Thermostat

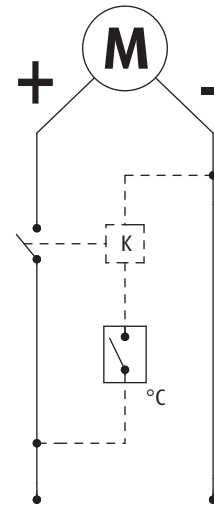

K= Relay
 °C= Thermostat

230V AC Monophase Electric Wiring

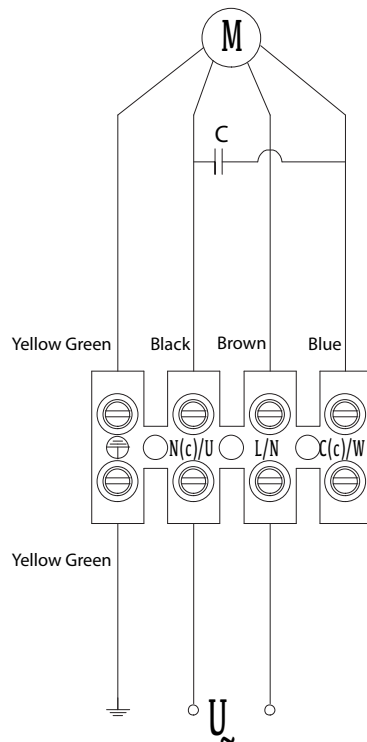

380V AC Threephase Electric Wiring

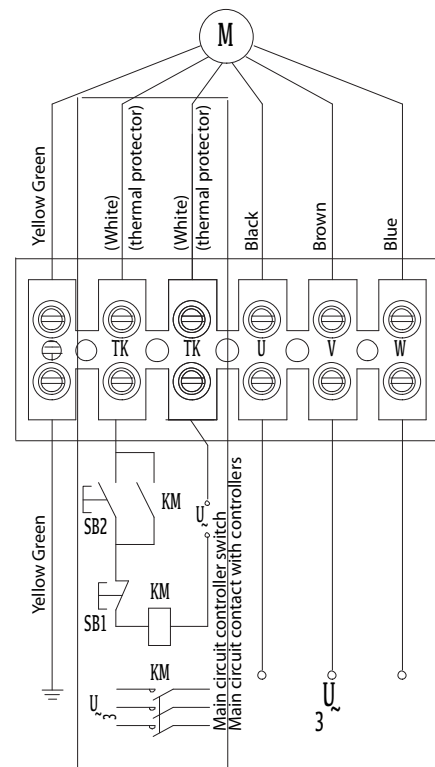

EXCHANGERS



OS2010-01A/T00F



1 Cooler Type

- OS2010
- OS2015
- OS2020
- OS2024
- OS2030
- OS2040
- OS2050

- OT0512
- OT0512
- OT1812
- OT2112

2 Fan Motor Type

- 01 220V 50/60Hz - Single Phase
- 03 380V 50/60Hz - Three Phase
- 12 12V DC
- 24 24V DC

3 Ventilating Type

- S Suction
- B Blowing

4 Thermostat

- | HFTS | HFTT | |
|------|------|------------------------------|
| T00 | T00 | Without thermostat |
| T01 | T11 | 40-28 C Fixed thermostat |
| T02 | T12 | 50-38 C Fixed thermostat |
| T03 | T13 | 60-48 C Fixed thermostat |
| T04 | T14 | 70-58 C Fixed thermostat |
| TOR | | 0-90 C Adjustable thermostat |

5 Mounting

- Without flange
- F Foot flange

Technical features

Product Code	Frequency Hz	Voltage V	RPM	Power kW	Current A	Q air (m/h)	dB (A)	Ø FAN mm	L mm	L1 mm	Cap. (lt)	Weight (kg)	IP
OS2015-015/T03F	50	230	2500	0,055	0,25	780	52	200	-	210	0.48	7	54
OS2015-035/T03F	50	400	2300	0,055	0,11	740	52	200	-	210	0.48	7	54
OS2015-245/T03F	DC	24	3000	0.10	4	994	66	225	158	-	0.48	6.5	65
OS2015-125/T03F	DC	12	3100	0.10	8,2	999	66	225	158	-	0.48	6.5	65

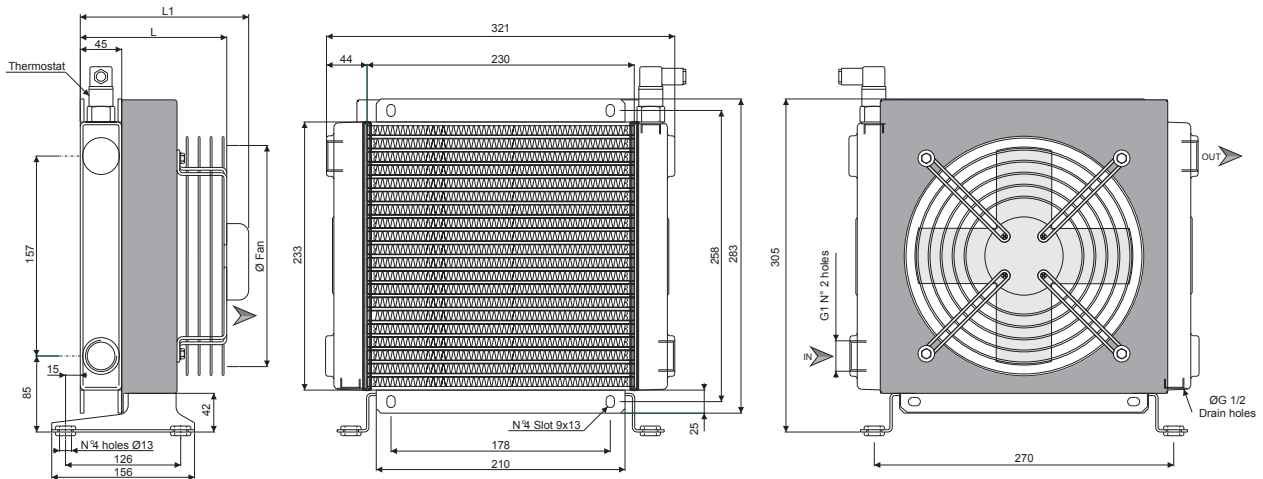

Correction factor - F - (Pressure drop)

CST	10	15	20	32	40	50	60	80	100	200	300
F	0.5	0.65	0.77	1	1.2	1.4	1.6	1.9	2.1	3.3	4.3

Pressure drop (ISO VG 32)

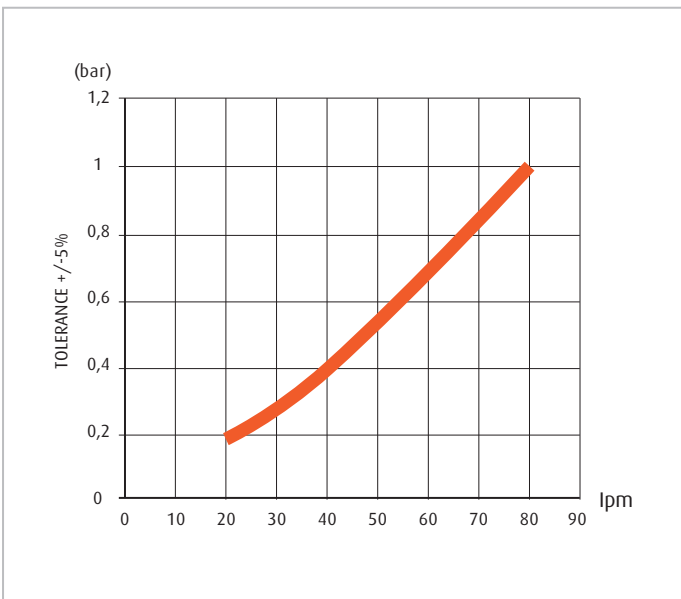

Performance diagram

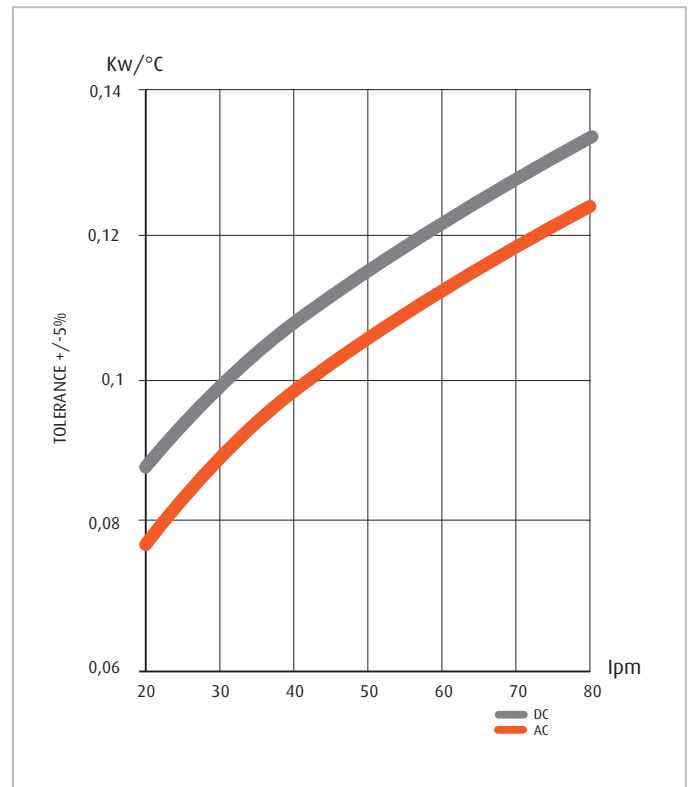

Technical features

Product Code	Frequency Hz	Voltage V	RPM	Power kW	Current A	Q air (m/h)	dB (A)	Ø FAN mm	L mm	L1 mm	Cap. (lt)	Weight (kg)	IP
OS2020-01S/T03F	50	230	2500	0,055	0,25	780	52	200	-	225	0,68	7,5	54
OS2020-03S/T03F	50	400	2300	0,055	0,11	740	52	200	-	225	0,68	7,5	54
OS2020-24S/T03F	DC	24	3000	0.10	4	994	66	225	177	-	0,68	7	65
OS2020-12S/T03F	DC	12	3100	0.10	8,2	999	66	225	177	-	0,68	7	65

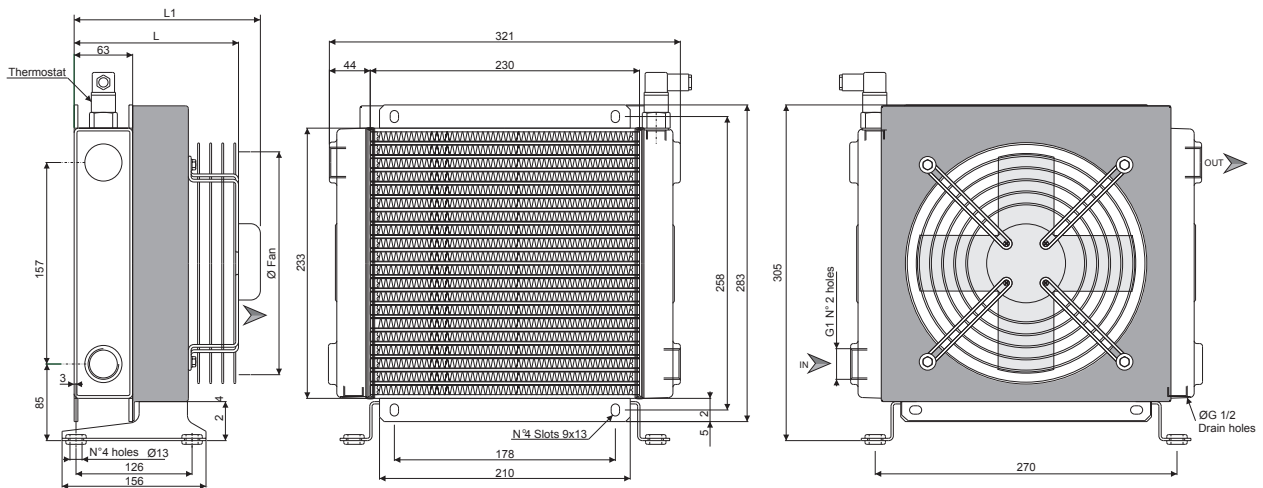

Correction factor - F - (Pressure drop)

CST	10	15	20	32	40	50	60	80	100	200	300
F	0.5	0.65	0.77	1	1.2	1.4	1.6	1.9	2.1	3.3	4.3

Pressure drop (ISO VG 32)

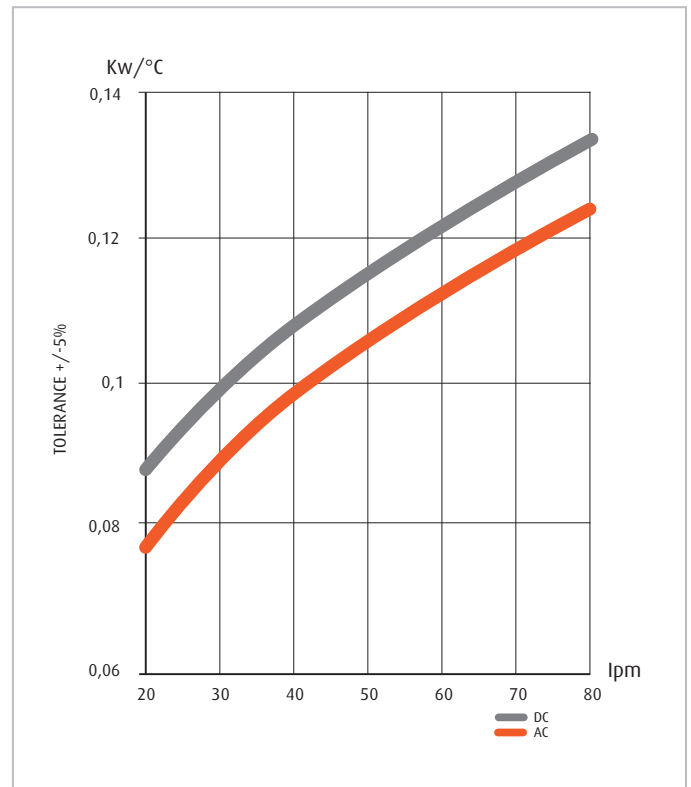
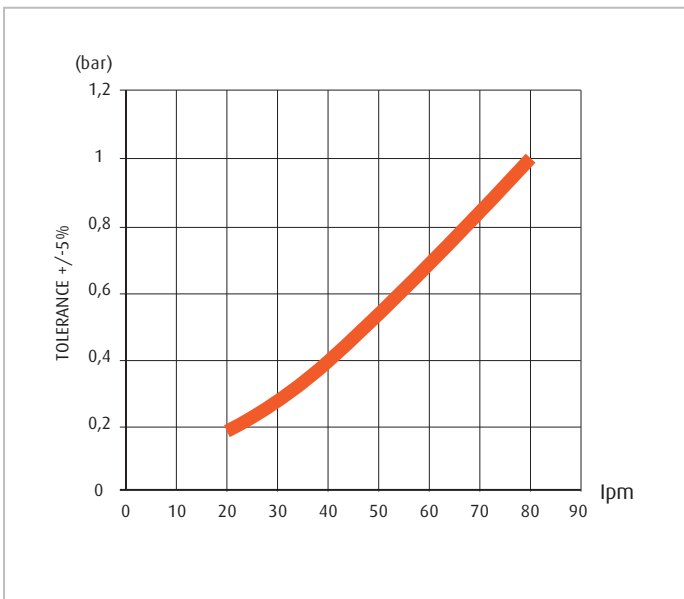

Technical features

Product Code	Frequency Hz	Voltage V	RPM	Power kW	Current A	Q air (m/h)	dB (A)	Ø FAN mm	L mm	L1 mm	Cap. (lt)	Weight (kg)	IP
OS2024-01S/T03F	50	230	2400	0,09	0,42	1530	60	250	-	240	0.9	11	54
OS2024-03S/T03F	50	400	2400	0,1	0,19	1550	60	250	-	240	0.9	11	54
OS2024-24S/T03F	DC	24	3000	0,125	5,2	1475	66	280	176	-	0.9	10	65
OS2024-12S/T03F	DC	12	3000	0,125	10	1400	66	280	176	-	0.9	10	65

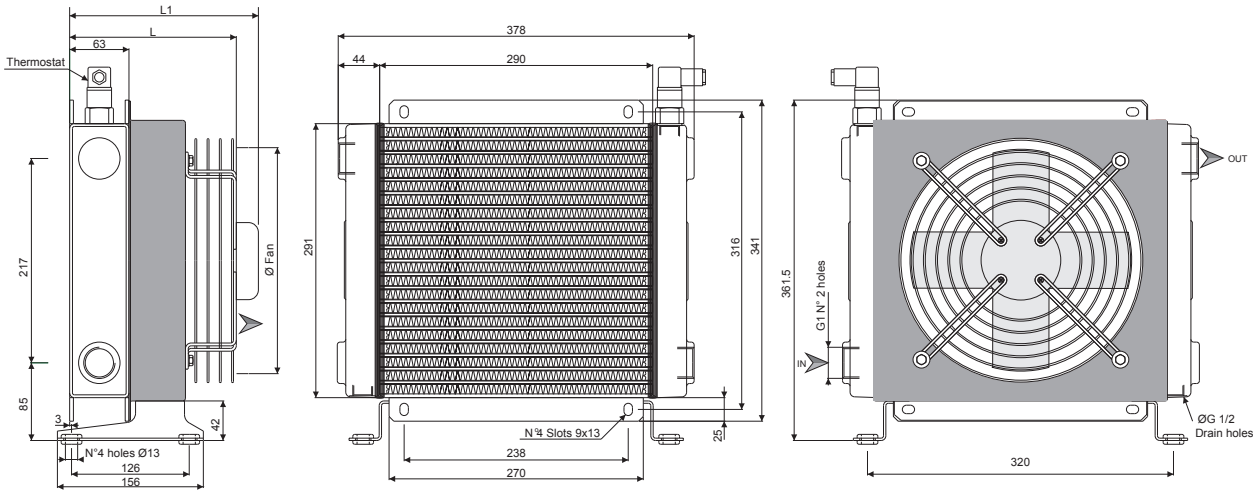

Correction factor - F - (Pressure drop)

CST	10	15	20	32	40	50	60	80	100	200
F	0,51	0,66	0,76	1	1,22	1,4	1,6	1,9	2,1	3,4

Pressure drop (ISO VG 32)

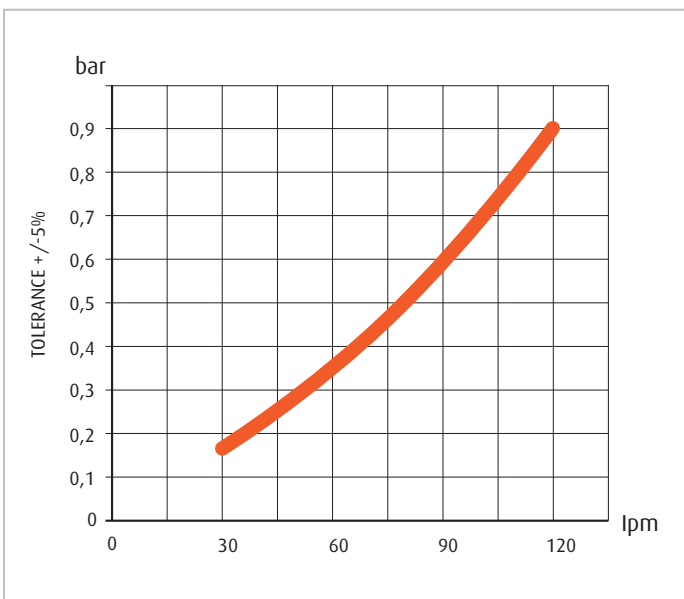

Performance diagram

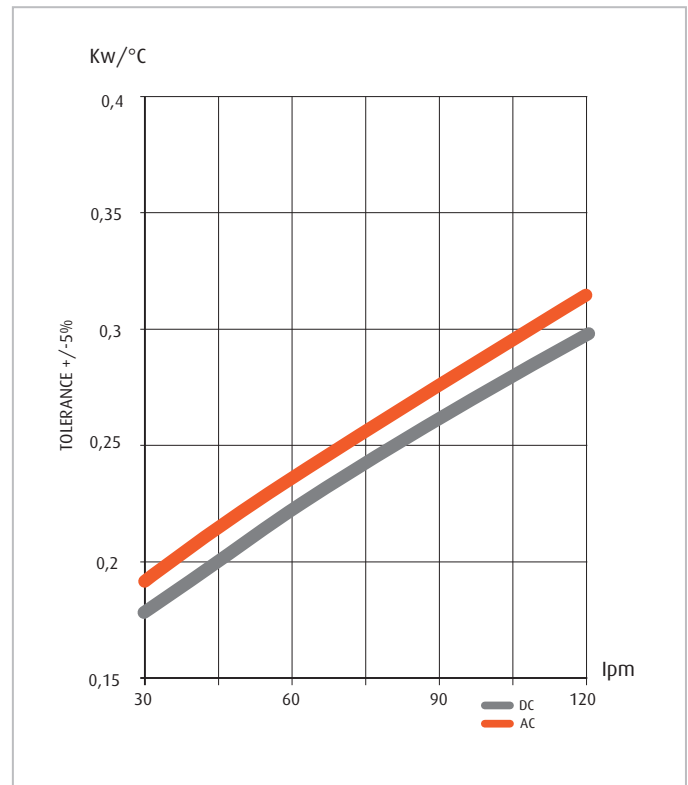

Technical features

Product Code	Frequency Hz	Voltage V	RPM	Power kW	Current A	Q air (m/h)	dB (A)	Ø FAN mm	L mm	L1 mm	Cap. (lt)	Weight (kg)	IP
OS2030-01S/T03F	50	230	2300	0,15	0,66	2400	62	300	-	250	1.5	15	54
OS2030-03S/T03F	50	400	2340	0,15	0,25	2150	62	300	-	250	1.5	15	54
OS2030-24S/T03F	DC	24	3000	0,24	10	2475	67	305	230	-	1.5	14	65
OS2030-12S/T03F	DC	12	3000	0,24	19	2400	67	305	230	-	1.5	14	65

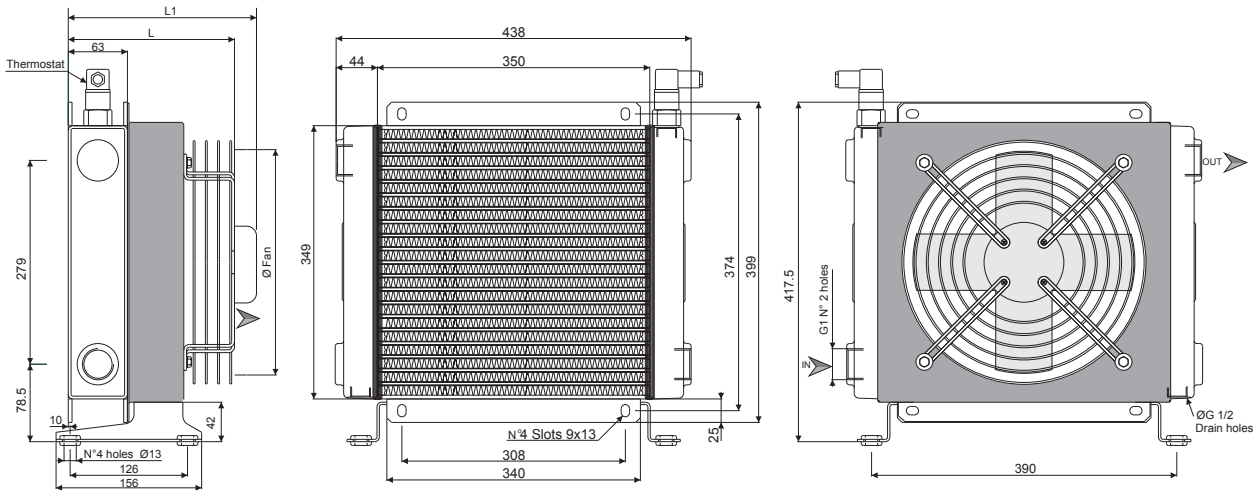

Correction factor - F - (Pressure drop)

CST	10	15	20	32	40	50	60	80	100	200	300
F	0.5	0.65	0.77	1	1.2	1.4	1.6	1.9	2.1	3.3	4.3

Pressure drop (ISO VG 32)

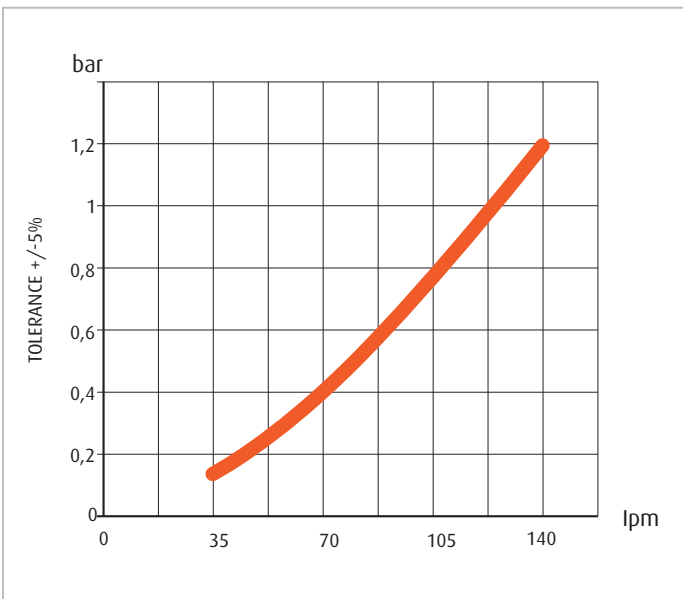

Performance diagram

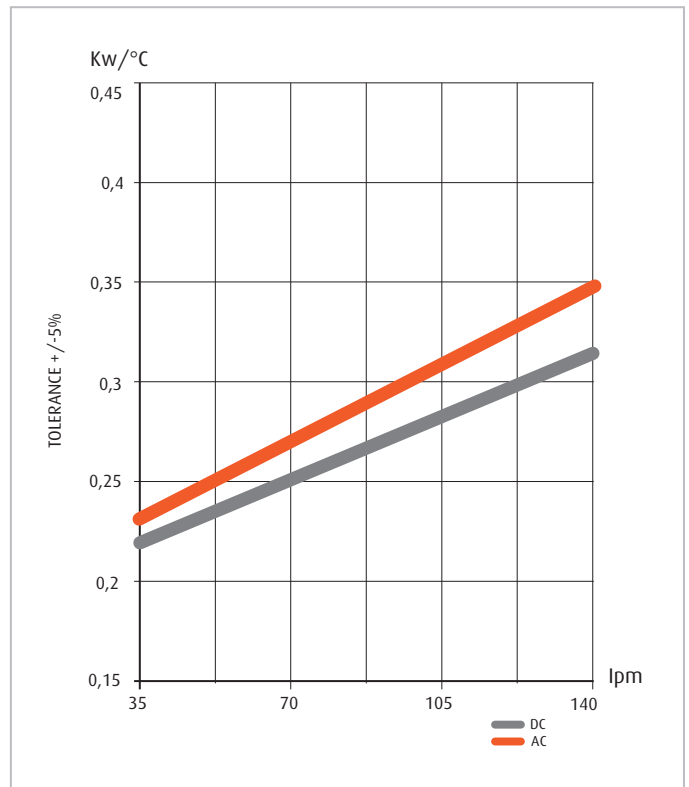

Technical features

Product Code	Frequency Hz	Voltage V	RPM	Power kW	Current A	Q air (m/h)	dB (A)	Ø FAN mm	L mm	L1 mm	Cap. (lt)	Weight (kg)	IP
OS2040-01S/T03F	50	230	1380	0,25	0,98	4500	68	400	-	270	2.6	21	54
OS2040-03S/T03F	50	400	1380	0,25	051	4550	68	400	-	270	2.6	21	54
OS2040-24S/T03F	DC	24	2500	0,24	9,5	3550	71	385	223	-	2.6	20	65
OS2040-12S/T03F	DC	12	2500	0,24	17	3200	69	385	223	-	2.6	20	65

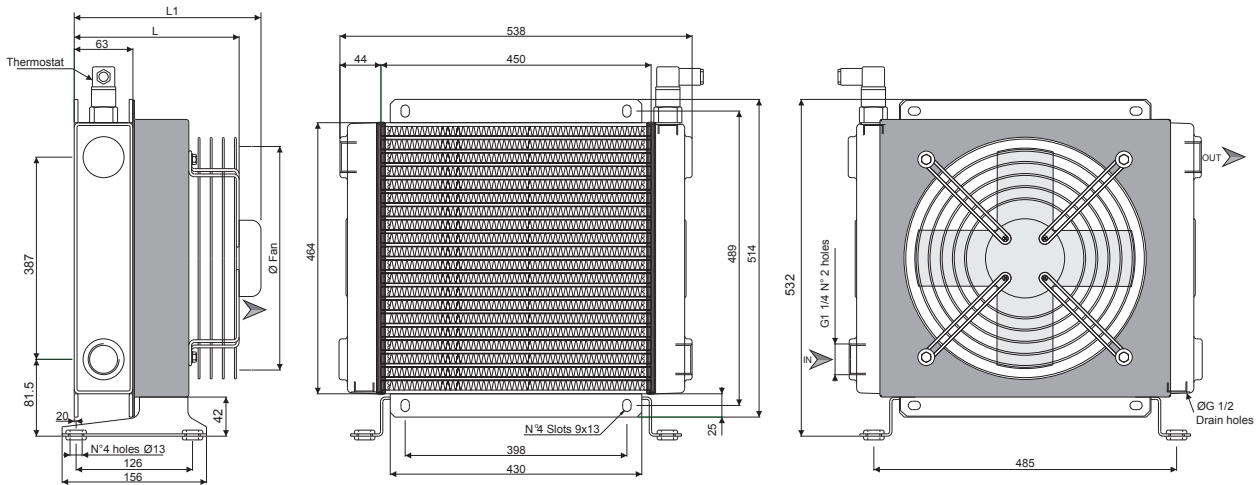

Correction factor - F - (Pressure drop)

CST	10	15	20	32	40	50	60	80	100	200
F	0,51	0,66	0,76	1	1,22	1,4	1,6	1,9	2,1	3,4

Pressure drop (ISO VG 32)

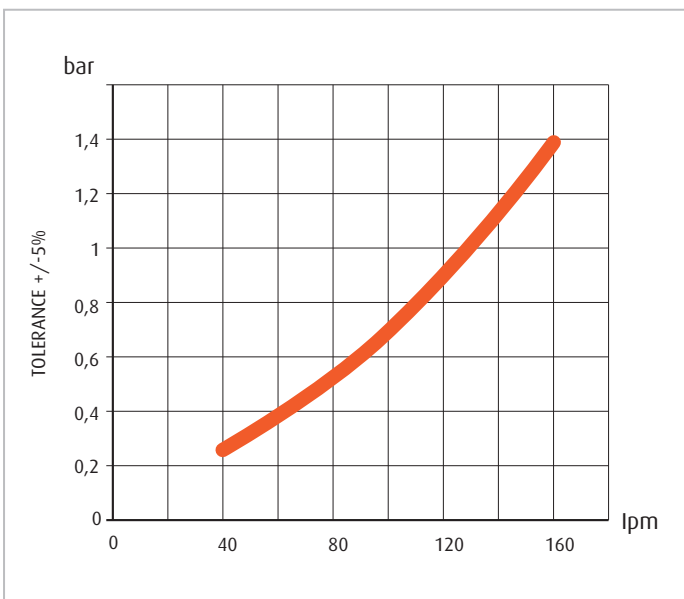

Performance diagram

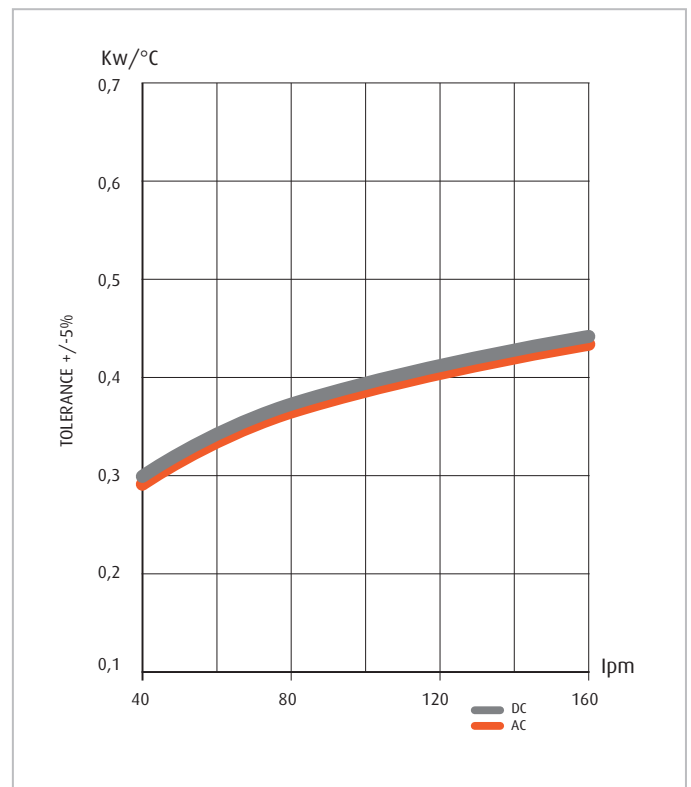

Technical features

Product Code	Frequency Hz	Voltage V	RPM	Power kW	Current A	Q air (m/h)	dB (A)	Ø FAN mm	L mm	L1 mm	Cap. (lt)	Weight (kg)	IP
OS2050-01S/T03F	50	230	1380	0,37	1,70	6200	70	450	-	298	4,9	27	54
OS2050-03S/T03F	50	400	1380	0,37	0,75	6500	70	450	-	298	4,9	27	54
OS2050-24S/T03F	DC	24	3000	0,125 (x2)	5,2 (x2)	1470 (x2)	73	280	195	-	4,9	24	65
OS2050-12S/T03F	DC	12	3000	0,125 (x2)	10 (x2)	1400 (x2)	73	280	195	-	4,9	24	65

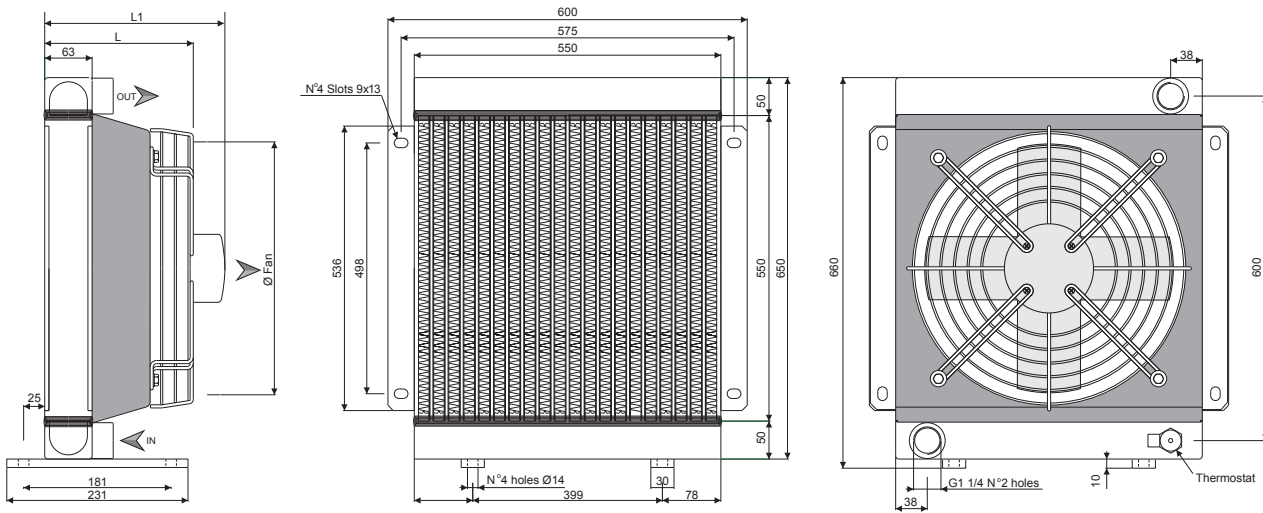

Correction factor - F - (Pressure drop)

CST	10	15	20	32	40	50	60	80	100	200	300
F	0.5	0.65	0.77	1	1.2	1.4	1.6	1.9	2.1	3.3	4.3

Pressure drop (ISO VG 32)

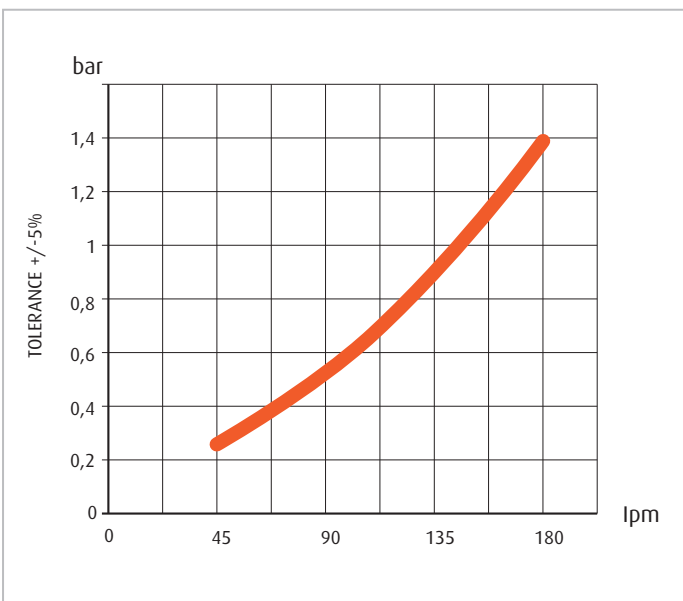

Performance diagram

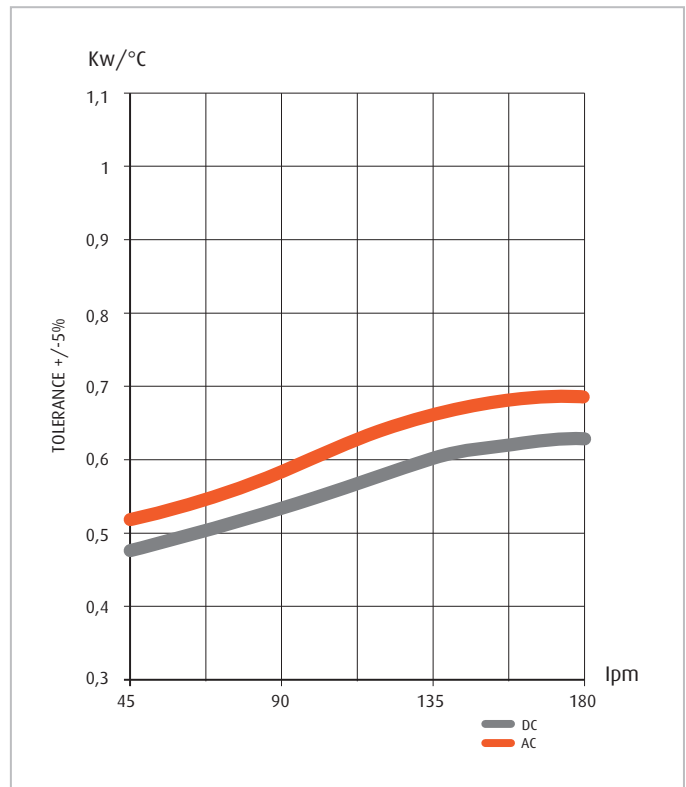

Technical features

Product Code	Frequency Hz	Voltage V	RPM	Power kW	Current A	Q air (m/h)	dB (A)	Ø FAN mm	L mm	Cap. (lt)	Weight (kg)	IP
OT0512A-T13F	DC	12	3790	0,09	7,2	710	73	190	139	0.48	6.5	68
OT0524A-T13F	DC	24	3790	0,09	3,2	720	73	190	139	0.48	6.5	68

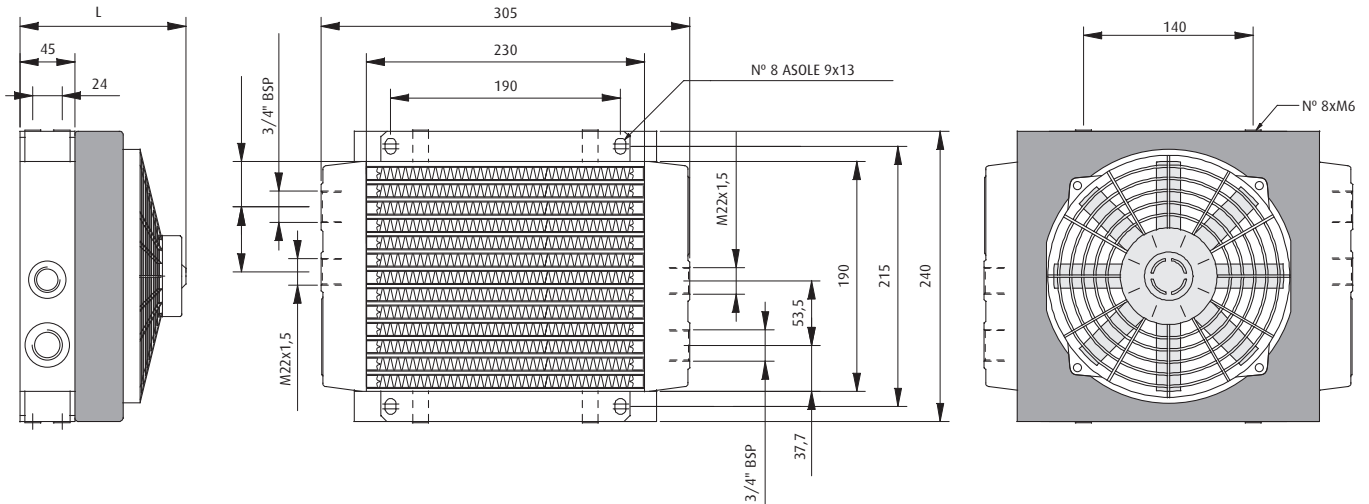

Correction factor - F - (Pressure drop)

CST	10	15	20	32	40	50	60	80	100	200
F	0,51	0,66	0,76	1	1,22	1,4	1,6	1,9	2,1	3,4

Pressure drop (ISO VG 32)

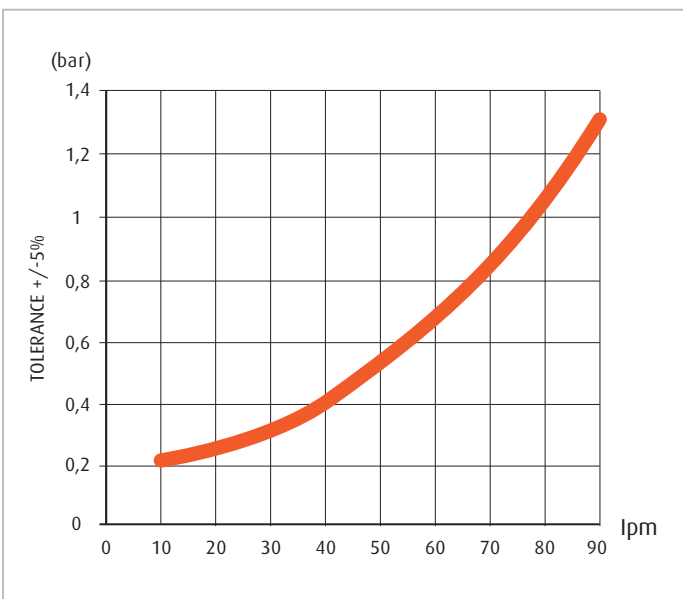

Performance diagram

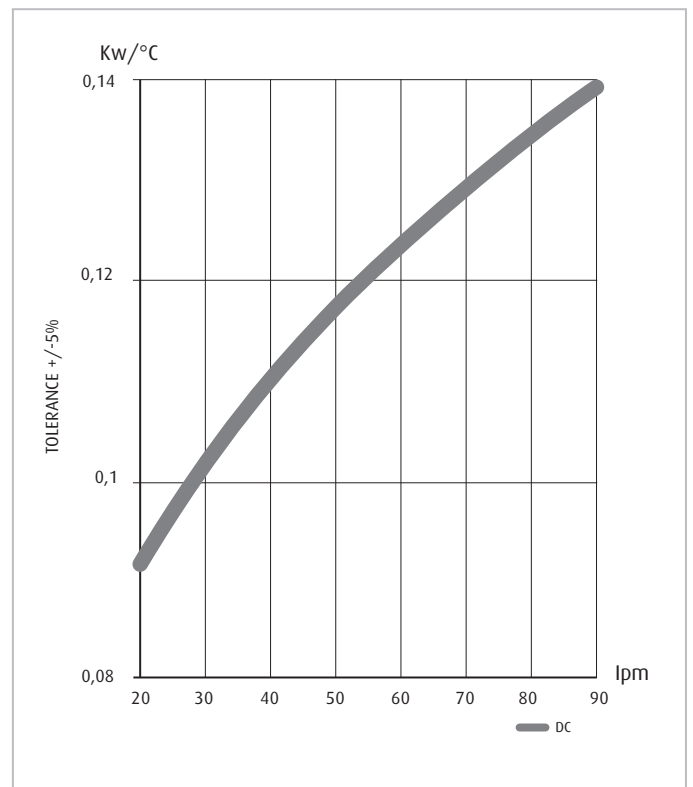

Technical features

Product Code	Frequency Hz	Voltage V	RPM	Power kW	Current A	Q air (m/h)	dB (A)	Ø FAN mm	L mm	Cap. (lt)	Weight (kg)	IP
OT0612A-T13F	DC	12	3090	0,17	6,9	2239	83	305	180	1.5	7.5	68
OT0624A-T13F	DC	24	3090	0,17	13,2	2324	83	305	180	1.5	7.5	68

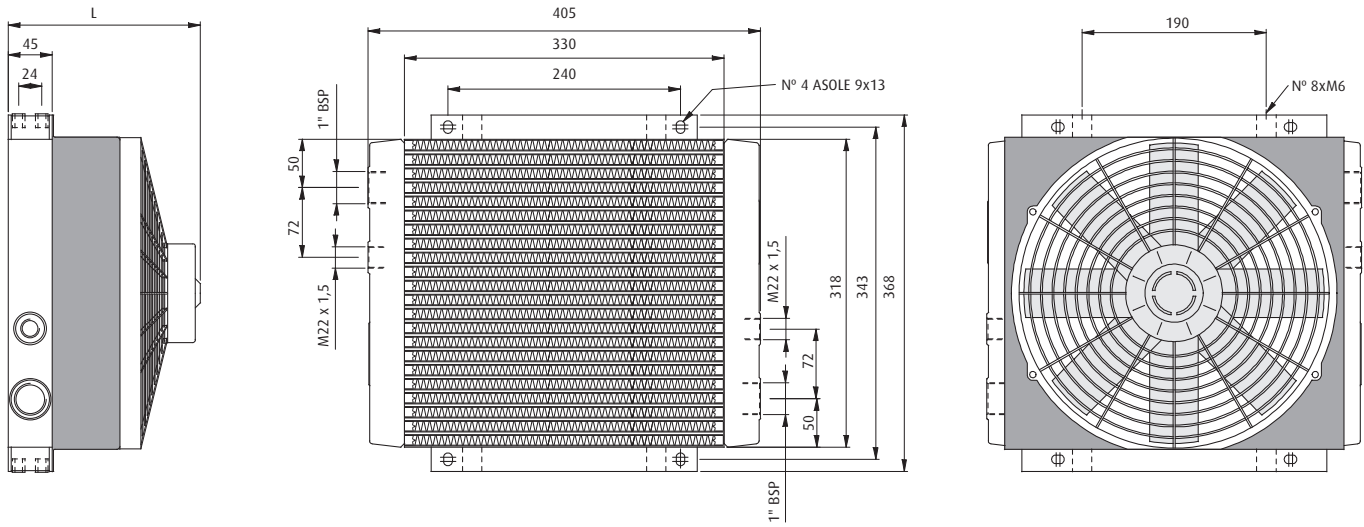

Correction factor - F - (Pressure drop)

CST	10	15	20	32	40	50	60	80	100	200	300
F	0.5	0.65	0.77	1	1.2	1.4	1.6	1.9	2.1	3.3	4.3

Performance diagram

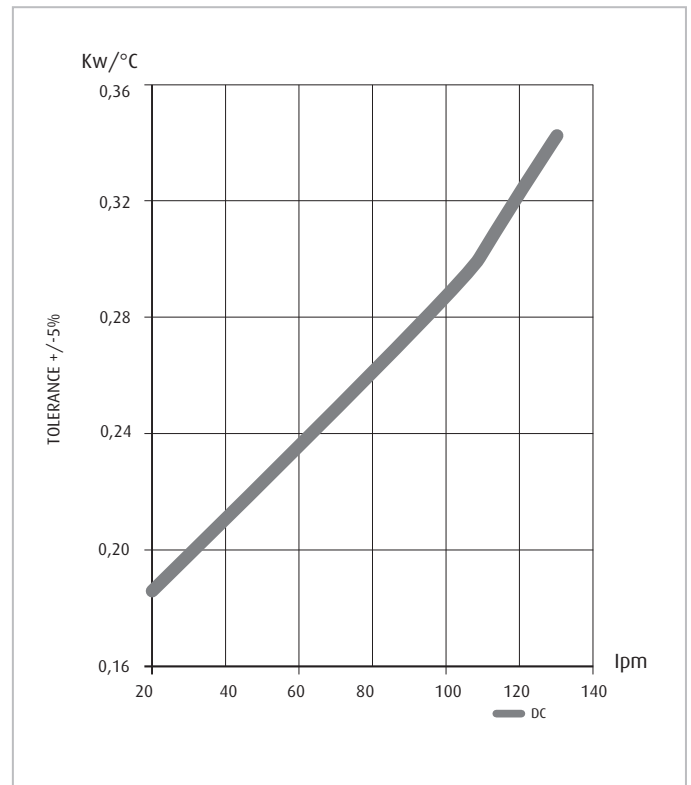

Pressure drop (ISO VG 32)

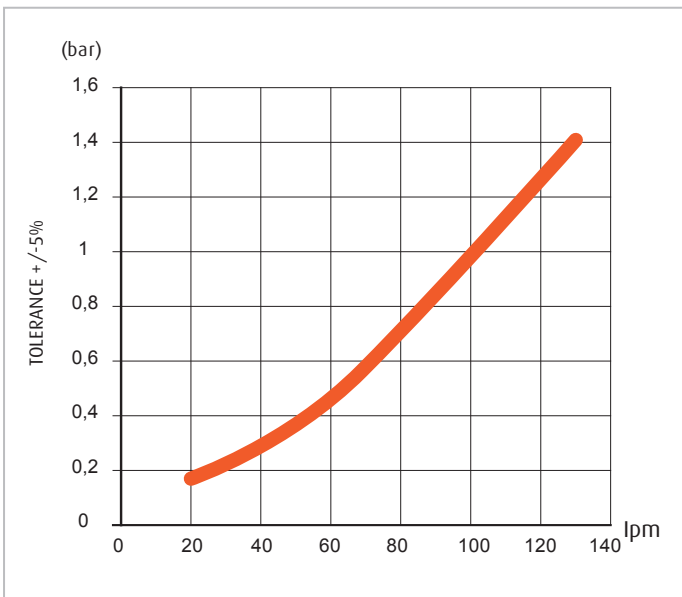

Technical features

Product Code	Frequency Hz	Voltage V	RPM	Power kW	Current A	Q air (m/h)	dB (A)	Ø FAN mm	L mm	Cap. (lt)	Weight (kg)	IP
OT1812A-T13F	DC	12	2248	0,17	7	2950	77	385	190	2.6	20	68
OT1824A-T13F	DC	24	2248	0,17	13	3100	77	385	190	2.6	20	68

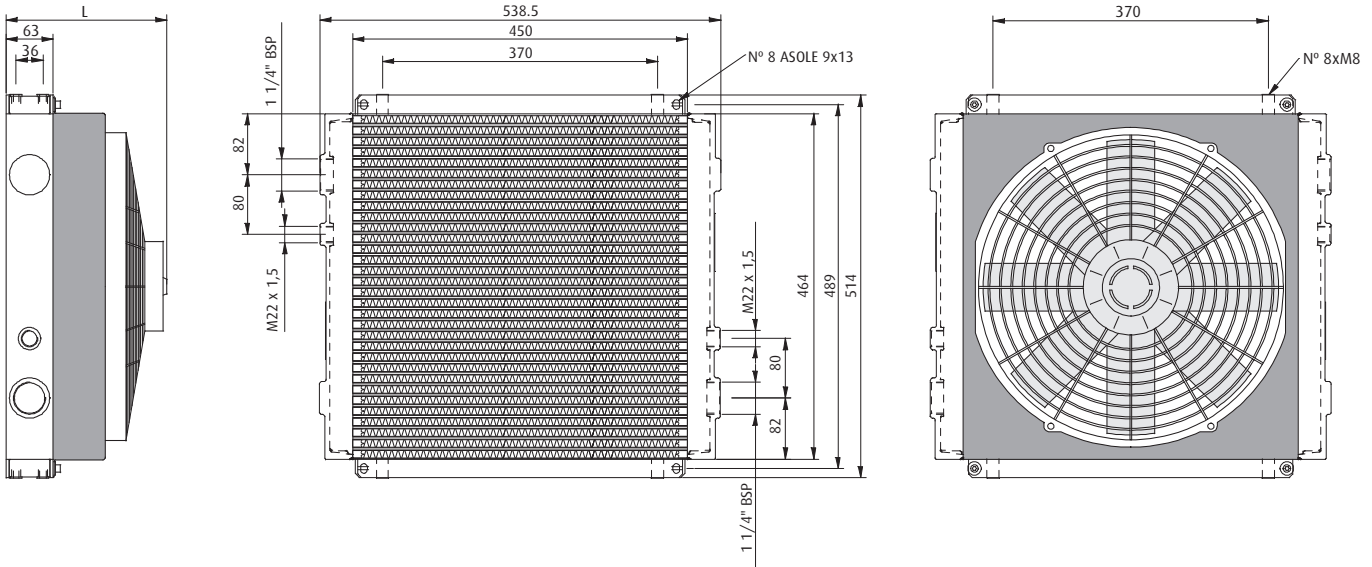

Correction factor - F - (Pressure drop)

CST	10	15	20	32	40	50	60	80	100	200
F	0,51	0,66	0,76	1	1,22	1,4	1,6	1,9	2,1	3,4

Pressure drop (ISO VG 32)

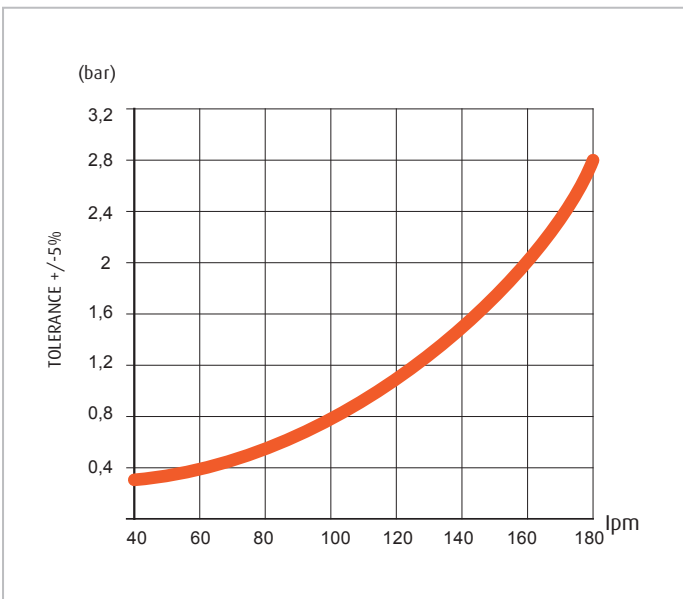

Performance diagram

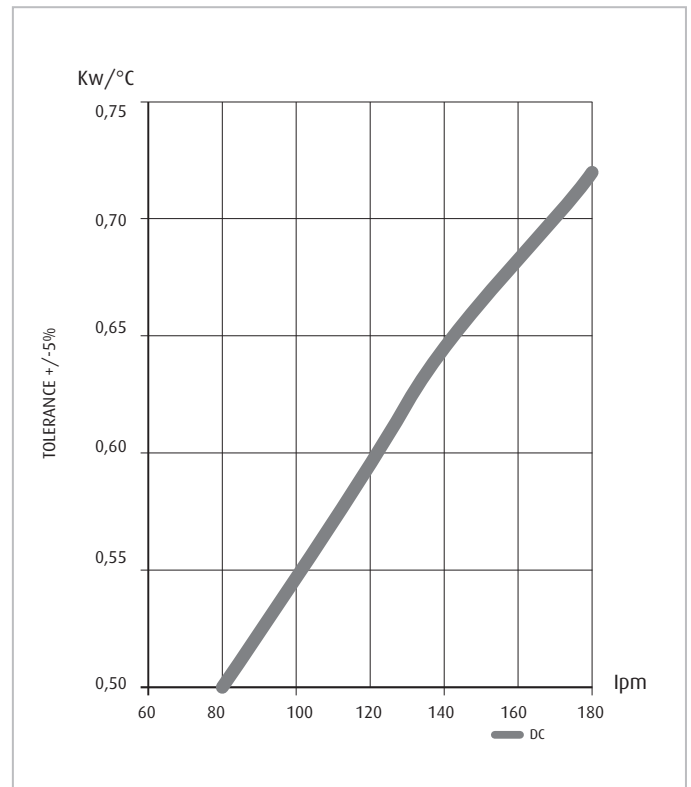

Technical features

Product Code	Frequency Hz	Voltage V	RPM	Power kW	Current A	Q air (m/h)	dB (A)	Ø FAN mm	L mm	Cap. (lt)	Weight (kg)	IP
OT2112A-T13F	DC	12	2248	0,24	17	3200	71	385	235	2.6	26	68
OT2124A-T13F	DC	24	2248	0,24	9,5	3550	69	385	235	2.6	26	68

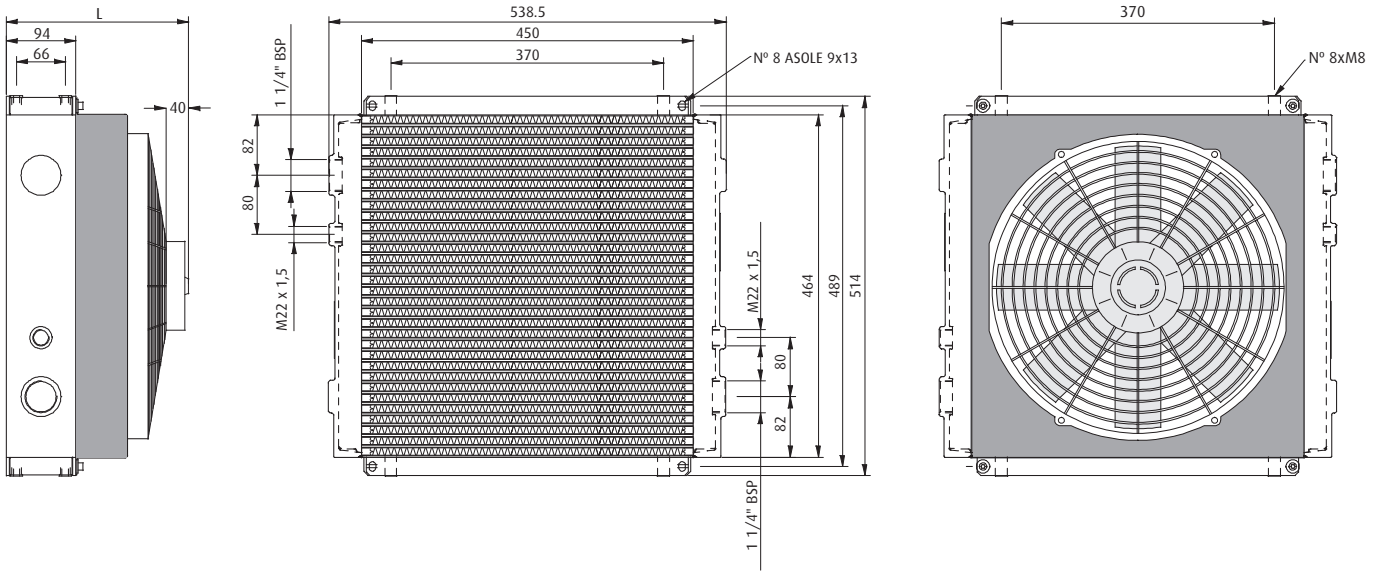

Correction factor - F - (Pressure drop)

CST	10	15	20	32	40	50	60	80	100	200	300
F	0.5	0.65	0.77	1	1.2	1.4	1.6	1.9	2.1	3.3	4.3

Pressure drop (ISO VG 32)

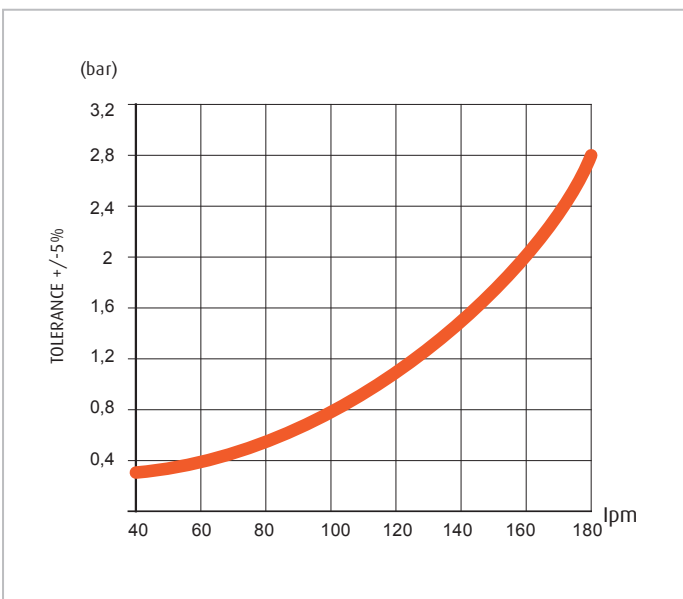

Performance diagram

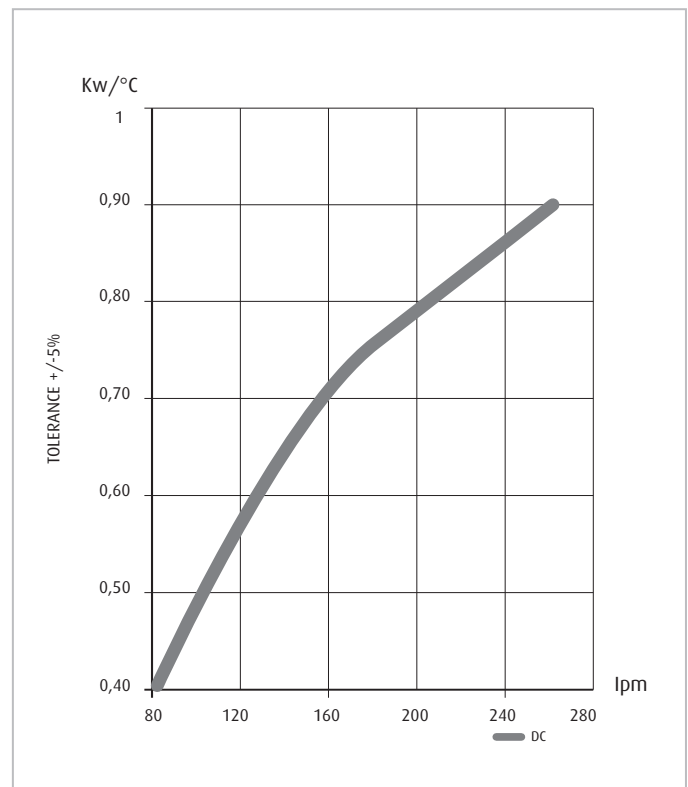

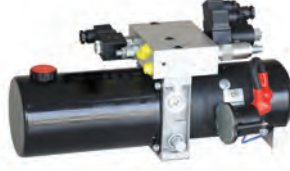

Hydraulic Power Packs



Hydraulic Valve Manifolds



Hydraulic Oil Heat Exchangers



Hydraulic Oil Tank & Accessories



OTTO TEKNİK SAN. TİC. LTD .ŞTİ.

Head Quarter

İkitelli OSB, Demirciler San. Sit.
B1 Blok No:39
Başakşehir/İSTANBUL/TURKEY
Phone. : +90212 671 63 07
E-mail : sales@ottoteknik.com.tr

Factory

Sivas OSB 12. Sok. No:1
SİVAS/TURKEY
T:+90 346 502 58 60
E-mail : sivas@ottoteknik.com.tr